

PREDICTIVE CONTROLLERS FOR THERMAL COMFORT OPTIMIZATION AND ENERGY SAVINGS

Roberto Z. Freire, roberto.freire@pucpr.br

Pontifical Catholic University of Paraná
Thermal Systems Laboratory - LST

Gustavo H. C. Oliveira, gustavo.oliveira@pucpr.br

Pontifical Catholic University of Paraná
Industrial and Systems Engineering Graduate Program - PPGEPS

Nathan Mendes, nathan.mendes@pucpr.br

Pontifical Catholic University of Paraná
Thermal Systems Laboratory - LST

Abstract. *The present work is focused on the control of indoor thermal comfort in buildings equipped with HVAC (Heating, Ventilation and Air Conditioning) systems. The occupants' thermal comfort sensation is addressed here by the well-known comfort index (PMV - Predicted Mean Vote). In this context, different strategies for the control algorithms are proposed by using only-one-actuator system that can be associated with a cooling and/or heating system. The first strategy is related to the thermal comfort optimization and the second one includes energy consumption minimization while maintaining the indoor thermal comfort criterion in an adequate level. The methods are based on the model predictive control scheme and simulation results are presented for different case studies in order to evaluate the controllers behavior when variations in occupants' clothing and metabolic rate occur. Results validate the proposed methodology in terms of both thermal comfort and energy savings.*

Keywords: *predictive control, thermal comfort, energy saving, HVAC systems.*

1 INTRODUCTION

Thermal comfort has a great influence on the productivity and satisfaction of indoor building occupants. The majority of HVAC systems for thermal comfort are based either on a single temperature control loop or, in some cases, on a multivariable temperature and relative humidity control loop. However, as far as thermal comfort optimization is concerned, other parameters should be considered in order to provide thermal satisfaction to the occupants. The interactions between people and the thermal environment are complex and have been the subject of much study, therefore, the science of thermal comfort are taking into account all these considerations [Fanger, 1970, Gagge *et al.*, 1986, Smith, 1991, ASHRAE, 2001, Jones, 2002].

As it is discussed further in this paper, thermal comfort in buildings is a concept difficult to define. Over the last decades, a large number of thermal comfort indices have been established for indoor climate analysis and HVAC control system design (see [ASHRAE, 2001]) and a quite disseminated one is the PMV (Predicted Mean Vote), proposed in [Fanger, 1970]. Such index considers environmental variables and individual factors and the closer to zero the PMV value, the better the occupants' thermal comfort sensation.

Associated to the thermal comfort concept, energy consumption is another important issue related to HVAC systems performance. Energy efficiency in buildings is nowadays an important issue due to the growth of energy costs, energy consumption and environmental impacts, especially those related to global warming. According to [EIA, 2004, Salsbury, 2005], in the United States and other developed countries, about one third of all energy use can be attributed to buildings. However, there is a trade-off between energy consumption and indoor thermal comfort, which relevance has been progressively attracting the attention of industrial and academic researches. The aim is to save energy while maintaining the occupants' thermal comfort.

In this way, the present paper proposes control strategies for reducing energy consumption and maintaining acceptable indoor air conditions related to thermal comfort. Therefore, one should first include the thermal comfort concept into the control law.

One idea related to the thermal comfort control approach is to assume a PMV sensor, so that the PMV is measured and controlled, *i.e.*, it is the feedback variable of an ordinary closed-loop structure. In [Kolokotsa *et al.*, 2001], a fuzzy control law is used and, in [Gouda *et al.*, 2001], a PID and a fuzzy controller are proposed and compared. In [Liang and Du, 2005], a direct neural network, capable to predict a comfort level (based on PMV) on specific user by learning the user's comfort zone, was used to maintain the indoor comfort level within the desired range. A different proposal, but still in the PMV-context, is presented in [Hamdi and Lachiver, 1998] and [Yonezawa *et al.*, 2000], where the control algorithm set-point is changed on-line or off-line as a function of the indoor PMV measurement. In those works, a

fuzzy logic expert system defines set-points for temperature and air velocity signals of a multivariable controller. Finally in [Nassif *et al.*, 2003], a genetic algorithm is used to find optimal set-point values of a HVAC system in order to reduce energy consumption, while maintaining thermal comfort within an acceptable range.

In [Freire *et al.*, 2005b], a first approach using PMV related to the MBPC (Model Based Predictive Control) law [Clarke, 1994, Camacho and Bordns, 1995] applied to a HVAC system, in order to optimize occupants thermal comfort sensation, is presented, where the manipulated variable is the input for the HVAC device. A system identification procedure have been performed using linear regression, for a heating system integrated to a building model, presented in [Freire *et al.*, 2005a]. The aim is obtaining a model that describes the HVAC system and building behaviour in a structure that is useful for advanced control law synthesis such as the MBPC. These models have been used in [Freire *et al.*, 2006] as an introduction to the PMV-based energy saving non-linear control scheme.

Here, two control schemes for improving the thermal comfort by using the PMV approach for measuring thermal comfort are addressed in the following sections. A characteristic of these schemes are the assumption of a SIMO (Single Input, Multiple Outputs) building system, where indoor temperature and relative humidity are measured variables and the single manipulated variable is the power applied to the HVAC device. Both schemes use model based predictive control (MBPC) fundamentals. The first one is a PMV-based-Predictive Control since it calculates the control signal that optimizes the PMV index in terms of thermal comfort and the second one optimizes the energy consumption maintaining the PMV index inside acceptable conditions.

This article is organized as follows. In the next section, concepts related to thermal comfort are reviewed. In Section 3, the proposed control laws are presented and in Section 4, some simulation results are presented in terms of two case studies: *i*) constant values for metabolic rate and cloth index and *ii*) occupants metabolic rates varying between low and moderate levels. Results are obtained by using a hourly weather data of a cold week in the city of Curitiba, Brazil. Finally, in Section 5, the conclusions are addressed.

2 THERMAL COMFORT

Definition and control of indoor conditions for reaching thermal comfort in buildings are hard to be established. As thermal satisfaction depends on several parameters, research works on thermal comfort have been conducted and some comfort indices have been proposed over the last fifty years. An example is the thermal comfort index called Effective Temperature, which is computed by using the indoor temperature and relative humidity signals and have been adopted by ASHRAE [ASHRAE, 2001] for decades.

A quite disseminated index for evaluating indoor thermal comfort is the PMV, which combines environmental variables and individual parameters. This index is based on a theoretical model combined with the results from experiments with approximately 1300 subjects, and is given by [Fanger, 1970]:

$$PMV = F(t_{bs}, t_{cl}, t_{rm}, h_c, f_{cl}, M, W, p_v) \quad (1)$$

$$PMV = (0.303 e^{-0.036M} + 0.028)\{(M - W) - 3.05 \times 10^{-3}[5733 - 6.99(M - W) - p_v]\} \\ - 0.42[(M - W) - 58.15] - [1.7 \times 10^{-5}M(5867 - p_v)] - [0.0014M(34 - t_{bs})] \\ - \{3.69 \times 10^{-8} f_{cl}[(t_{cl} + 273)^4 - (t_{rm} + 273)^4]\} - [f_{cl}h_c(t_{cl} - t_{bs})] \quad (2)$$

where t_{bs} ($^{\circ}C$) is the dry-bulb temperature or just indoor air temperature, t_{cl} ($^{\circ}C$) is the clothing surface temperature, t_{rm} ($^{\circ}C$) is the mean radiant temperature, h_c (W/m^2K) is the convective heat transfer coefficient that is calculated as shown on Equation (3). f_{cl} is the clothing area factor, which can be computed by means of a cloth index, given by I_{cl} [Fanger, 1970]. M (W/m^2) is the metabolic rate, the rate of transformation of chemical energy into heat and mechanical work by aerobic and anaerobic activities within the body and W (W/m^2) is the effective mechanical power.

$$h_c = 10.4\sqrt{v}, \text{ for } v < 2.6 \text{ m/s} \quad (3)$$

The term t_{cl} can be computed iteratively by the following equation:

$$t_{cl} = 35.7 - 0.032M - 0.18I_{cl}(3.4f_{cl} \times ((t_{cl} + 273)^4 - (t_{rm} + 273)^4) + f_{cl}h_c(t_{cl} - t_{bs})) \quad (4)$$

Therefore, combining Equations (2) to (4), the PMV index can be written as a function of four environmental variables (temperature: t_{bs} , relative humidity: ϕ , mean radiant temperature: t_{rm} and air velocity: v) and two individual parameters (metabolic rate: M and cloth index: I_{cl}), as follows:

$$PMV = G(t_{bs}, \phi, t_{rm}, v, M, I_{cl}) \quad (5)$$

Table 1 shows the relationship among PMV and thermal sensation. In 1994, this formulae was included in ISO Standard 7730 and a PMV-based criterion has been established between -0.5 and $+0.5$ as acceptable for thermal comfort in air-conditioned environments. Also, in this table, PPD means Predicted Percentage of Dissatisfied and it is an indication of the percentage of people who could complain about the thermal quality of a given indoor environment.

Table 1. Relationship between PMV, PPD and thermal sensation [Fanger, 1970].

PMV	Thermal Sensation	PPD (%)
+3	Hot	100
+2	Warm	75
+1	Slightly warm	25
0	Neutral	5
-1	Slightly cool	25
-2	Cool	75
-3	Cold	100

3 MODEL BASED PREDICTIVE CONTROL LAWS FOR THERMAL COMFORT AND ENERGY SAVINGS

Based on the previous section discussions, the aim of a thermal comfort based control law is to keep the indoor hygrothermal conditions within the PMV-based comfort bounds. Moreover, there is a trade-off between thermal comfort optimization and energy consumption. Classical control strategies usually can't provide these benefits to a single-zone building. The MBPC (Model Based Predictive Control) technique make possible to minimize both problems when cost functions and constraints are adequately implemented. This will be presented in following.

The model based predictive control strategy can't be defined as specific control law, but can be viewed as a strategy which uses several control methods linked by means of some common ideas [Clarke, 1994, Camacho and Bordns, 1995]. The methodology is related to controllers which presents almost the same structure and characteristics in common, that is, MPC or MBPC controllers are defined by the process model, which is obtained for control purposes, and are characterized by the following four main steps:

- i) Process modelling: where data from input (manipulated) and output (controlled) signals are used to predict the process behaviour (output prediction) in a future horizon, defined as prediction horizon (N_y).
- ii) Cost function definition: where the system closed-loop performance during the prediction horizon is specified. It is defined by using the output prediction, the reference signal and the control effort.
- iii) Cost function optimization: the cost function is optimized as a function of the set of future control signals (control horizon - N_u) to be applied to the process during the prediction horizon. In this step, constraints in the manipulated and controlled variable can be added in order to deal with the system operation constraints, *e.g.*, limits on the actuators of the HVAC system.
- iv) Receding horizon strategy: only the first control signal computed from the cost function optimization is applied to the real process and, in the next step time, all the algorithm is repeated.

The present work deals with MBPC for thermal comfort and the generic scheme for the MBPC controllers is shown in Fig. 1. The way how thermal comfort issue is included in the control law is based on the PMV index. This is the main points that makes the controllers presented in this paper different from the classical MBPC laws. The models are defined by a MISO (*Multiple-Input/Single-Output*) ARMAX (*Auto-Regressive with Exogenous Input*) representation of a building coupled to the HVAC system. The manipulated input signal is $u(k)$, which represents the signal applied to a heating/cooling system and the disturbance inputs are the outdoor temperature ($T_{EXT}(k)$), outdoor relative humidity ($H_{EXT}(k)$) and total solar radiation ($S_{EXT}(k)$). Finally, the controlled output signals are the indoor temperature ($y_T(k)$) and indoor relative humidity ($y_H(k)$). The two models are presented in Equation 6.

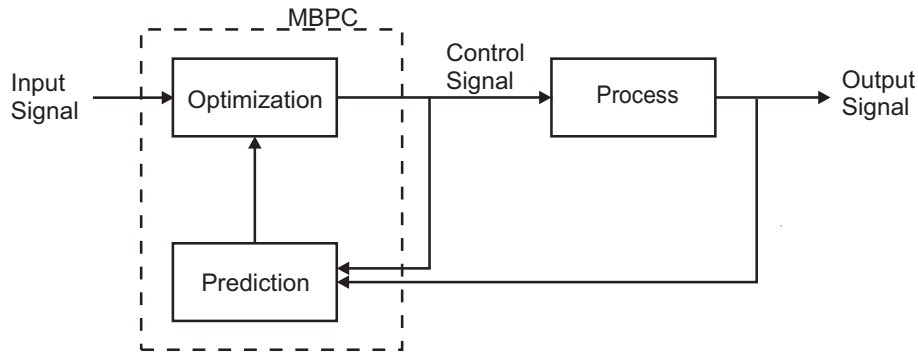

Figure 1. MBPC controllers scheme.

$$A_i(q)y_i(k) = B_i(q)u(k) + B_{T,i}(q)T_{EXT}(k) + B_{H,i}(q)H_{EXT}(k) + B_{S,i}(q)S_{EXT}(k) + C_i(q)\xi_i(k) \quad (6)$$

where $i = T$ or H representing the indoor temperature and indoor relative humidity models. $\xi_i(k)$ is a random disturbance signal, zero mean, variance σ . The modelos parameters are given by the $A_i(q)$, $B_i(q)$, $B_{T,i}(q)$, $B_{H,i}(q)$, $B_{S,i}(q)$ and $C_i(q)$ which have the following form:

$$\begin{aligned} A_i(z) &= 1 + a_1q^{-1} + a_2q^{-2} + \dots + a_{n_a}q^{-n_a} \\ B_i(z) &= b_0 + b_1q^{-1} + b_2q^{-2} + \dots + b_{n_b}q^{-n_b} \\ C_i(z) &= 1 + c_1q^{-1} + c_2q^{-2} + \dots + c_{n_c}q^{-n_c} \end{aligned} \quad (7)$$

The PMV approach leads to a non-linear representation for the process model, since its output is obtained by the non-linear PMV computation. In this case the model is represented by a series structure made with the linear model that relates the input signal and the temperature and relative humidity output signals followed by a non-linear static operator that transform this signals in the PMV index. This kind of structure is known as a non-linear *Wiener* model, as shown by Fig. 2.

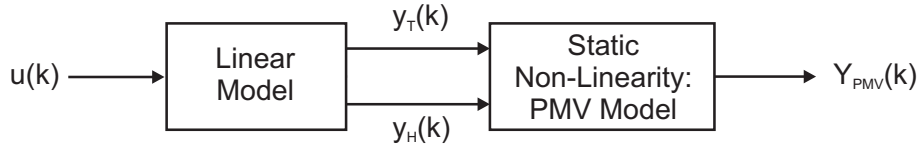

Figure 2. Representation of a Wiener structure.

Following, the MBPC PMV-based algorithms which are responsible for maintaining acceptable indoor thermal comfort conditions, are proposed. One of these algorithms is also capable to minimize energy consumption by setting PMV bounds for the indoor air conditions.

3.1 Algorithm based on PMV optimization

Following, a control strategy is described where the building occupants thermal comfort sensation is given by PMV calculations. The PMV predictions computed by using the non-linear model are included in the cost function, and as discussed in Section 2, the closer to zero the PMV value, the better the thermal sensation. Therefore, the control law is given by the following optimization problem:

$$\begin{aligned} \min_{\Delta u(k|k), \dots, \Delta u(k+N_u-1|k)} & \sum_{j=1}^{N_y} (\hat{y}_{PMV}(k+j|k))^2 + \sum_{j=0}^{N_u-1} \lambda \Delta u^2(k+j|k) \\ \text{s.to} & \\ & \Delta u(k+j|k) = 0 \quad \forall j = N_u, \dots, N_y \\ & u_{\min} \leq u(k+j|k) \leq u_{\max} \quad \forall j = 1, \dots, N_u \end{aligned} \quad (8)$$

The first constraint set is related to the control horizon, while the second one is the constraint over the control signal, imposed by the HVAC device. In this way, the solution of Problem (8) given by means of N_u future values for the control signal variation is $u(k) = \Delta u(k|k) + u(k-1)$. Since Problem (8) is a non-linear optimization problem with non-linear constraints, its solution can be obtained by using a sequential quadratic programming algorithm.

3.2 Algorithm based on setting PMV signal boundaries minimizing energy consumption

Following, a control strategy which adopts the building occupants thermal comfort sensation as boundaries for the PMV signal is presented. As discussed in Section 3.1, this algorithm is also based on a non-linear structure (the *Wiener* structure presented in Fig. 2).

Following ASHRAE standards [ASHRAE, 2001], built environment is comfortable in terms of thermal comfort when PMV is between the boundaries $-0.5 \leq PMV \leq +0.5$. Based on these limits for PMV, the control law for this case can be presented as follows:

$$\begin{aligned} \min_{\Delta u(k|k), \Delta u(k+1|k), \dots, \Delta u(k+N_u-1|k)} & u^2(k) \\ \text{s.to} & \\ & \Delta u(k+j|k) = 0 \quad \forall j = N_u, \dots, N_y \\ & u_{\min} \leq u(k+j|k) \leq u_{\max} \quad \forall j = 1, \dots, N_u \\ & y_{PMV, \min} \leq \hat{y}_{PMV}(k+j|k) \leq y_{PMV, \max} \quad \forall j = 1, \dots, N_y \end{aligned} \quad (9)$$

where $y_{PMV, \min}$ and $y_{PMV, \max}$ represent the boundaries for PMV associated to the thermal comfort conditions. In this problem, the cost function is related to the energy consumption. The third constraints set assures that the PMV signal will be between the specified boundaries, providing thermal comfort.

This problem assures, at each sample time, an optimal control signal, minimizing energy consumption while maintain the PMV inside the thermal comfort range. Similar to Problem (8), the optimal control signal can be obtained by a sequential quadratic optimization algorithm.

4 SIMULATION RESULTS

In order to evaluate the performance of the previous thermal comfort MBPC control strategies presented in this paper, a single-zone building used by the BESTest methodology [IEA, 2003], as shown in Fig. 3, has been adopted.

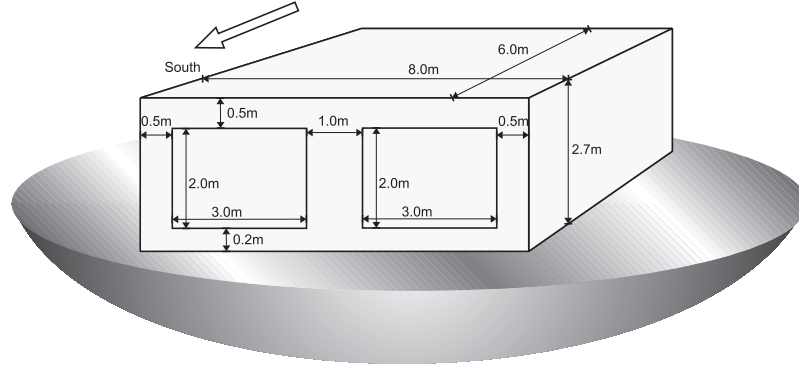

Figure 3. Building Model.

In this way, the BESTest single-zone building has been simulated using PowerDomus [Mendes *et al.*, 2005], which is a whole-building hygrothermal and energy simulation software based on a lumped formulation where in the energy balance are considered sensible and latent conductive heat transfer loads, convective heat transfer, long- and short-wave radiation, infiltration, ventilation and loads related to the HVAC system among other parameters. Therefore, the building model presented in Fig. 3, implemented in PowerDomus, acts as an actual building for the identification and control experiments, where the external climate is captured from a TRY (Test Reference Year) weather data (external temperature - T_{EXT} , external relative humidity - H_{EXT} , total solar radiation - S_{EXT}) of the city of Curitiba, Brazil. By means of least-square based identification procedures [Ljung, 1999], the following equations for the combined HVAC (a heating system of 5kW maximum power) and building envelope model under analysis were obtained [Freire *et al.*, 2005a, Freire, 2006].

$$(1 - 0.97000q^{-1}) y_T(k) = (0.08395q^{-1}) u'(k) + (0.02527q^{-1}) T_{EXT}(k) + (0.20340q^{-1}) H_{EXT}(k) + (-0.07245q^{-1}) S_{EXT}(k) + (1 + 0.67670q^{-1}) \xi_T(k) \quad (10)$$

$$(1 - 0.96920q^{-1}) y_H(k) = (-0.002107q^{-1}) u'(k) + (0.0002751q^{-1}) T_{EXT}(k) + (0.01759q^{-1}) H_{EXT}(k) + (0.003342q^{-1}) S_{EXT}(k) + (1 + 0.72390q^{-1}) \xi_H(k) \quad (11)$$

In Equations. (10) and (11), the units for temperature is [$^{\circ}C$] and the sampling time is 1 minute. In these models, $u'(k)$ is given by:

$$u'(k) = u(k) + u_P(k) \quad (12)$$

where $u(k)$ is the manipulated signal provided by the control law and $u_P(k)$ is a disturbance representing the heating generated by the building occupants.

Now, some closed-loop results are presented, by using two case studies. In all cases, the controller is turned on at the 0-th hour of the third day (time equal to 48 hours - two days of warm-up simulation period) and the simulation period is 1 week (168 hours). The controller parameters are: $N_y = 10$ and $N_u = 1$. It is assumed here a heating system, therefore, $u(k)$ is constrained to the limits [0,5]. The external climate data adopted during the closed-loop simulations, *i.e.*, temperature, relative humidity and total solar radiation, are shown in Fig. 4. For the first case study, the results are related to the analysis of the properties of the control schemes presented in Section 3, where the main objective is to maintain the best thermal comfort conditions with or without energy consumption reduction. In the sequence, *i.e.*, in the second case study, the control schemes are discussed and the effect of changes on the occupants' metabolic rate and cloth index is also analyzed.

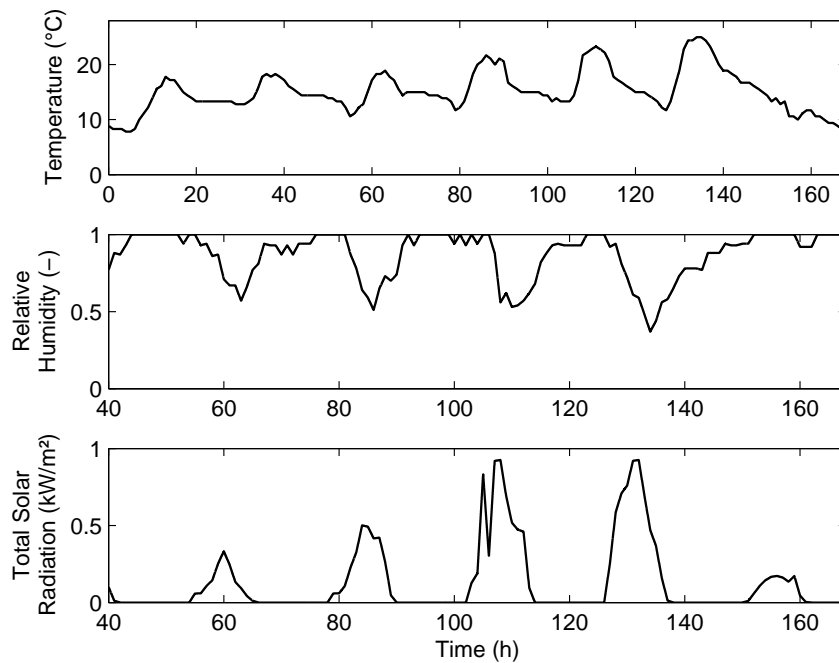

Figure 4. External temperature, relative humidity and total solar radiation for the simulation period in Curitiba - Brazil.

4.1 Case Study I - Controller Performance Analysis

The control strategies presented in Sections 3.1 and 3.2 are evaluated in terms of temperature, relative humidity, PMV and energy consumption. In this case, two occupants are considered inside the building environment, where their clothing index and metabolic rate are constant equal to 0.66 *clo* and 1.20 *met*. These values are related to usual office clothing and metabolic rate [ASHRAE, 2001].

Figures 5 and 6 present the results obtained by using the controller based on the PMV index. The optimal PMV index is obtained by the controller presented in Fig. 5 (Solution 1). It can be seen by Tab. 2 that this is the case where the PMV is closer to zero. Figure 6 (Solution 2) presents a controller that include energy reduction minimization. The constraints over the PMV index are set equal to $[-0.5, 0.5]$. As expect, the energy consumption is lower than in the previous solution.

Table 2. Energy consumption for the five day simulation period and quadratic sum of the *PMV* for the controller without energy consumption minimization.

Solution	Energy Consumption (kWh)	$\sum PMV^2$
1	174.77	10.6897
2	98.67	-

4.2 Case Study II - Varying Metabolic Rate and Clothing Index

In this section, the performances of the controllers are analyzed when variations on metabolic rate and clothing index occur.

In Figs. 7 and 8, the results are presented in terms of indoor temperature, indoor relative humidity, PMV and energy consumption. Variations on the metabolic rate and clothing index are presented in Tab. 3, where during the day (from 7 am to 10 pm), the occupants' metabolic rate is equivalent to a physical activity of a person working in an office, while, at night (from 10 pm to 7am), it is assumed the occupants are sleeping.

Table 3. Case Study II - variations on metabolic rates and clothing index.

State	I_{cl} (clo)	M (met)
I	0.66	1.20
II	0.45	0.80

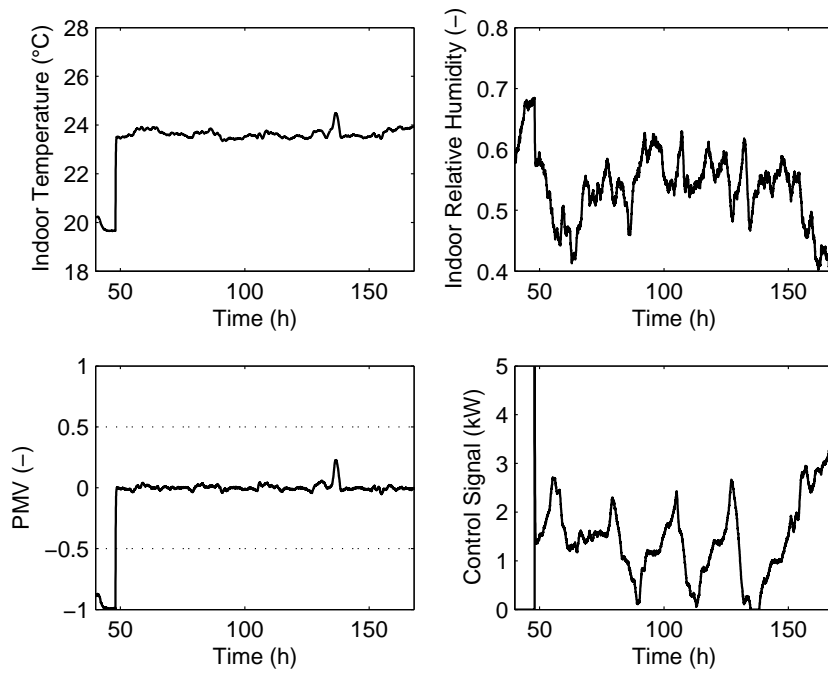

Figure 5. Case Study I - Indoor temperature, indoor relative humidity, PMV and control signal for the algorithm based on PMV optimization.

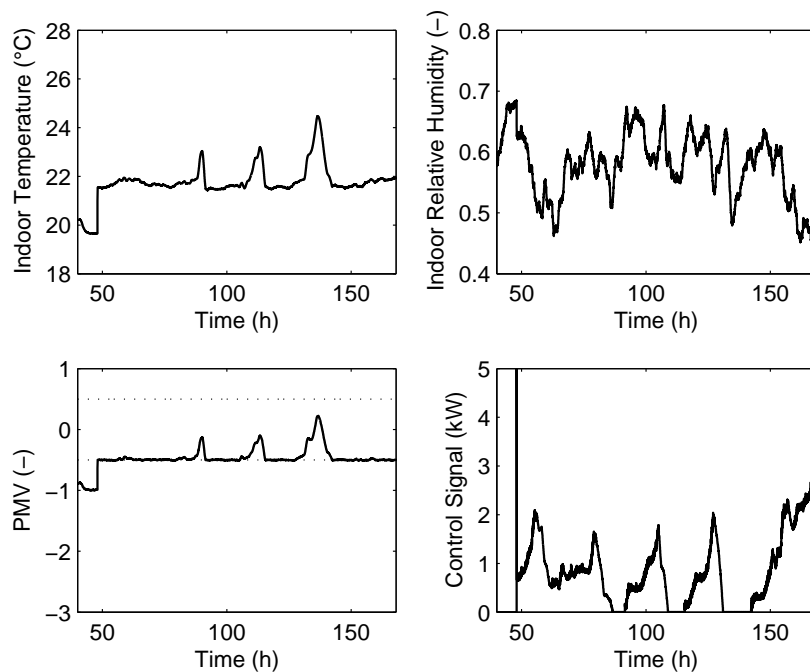

Figure 6. Case Study I - Indoor temperature, indoor relative humidity, PMV and control signal for the algorithm based on setting PMV signal boundaries minimizing energy consumption.

By analyzing the results in terms of temperature, it can be noticed that the controllers (Fig. 7 and 8), increase the indoor temperature during the period when metabolic rate is low, in order to provide a better thermal comfort sensation. When the metabolic rate becomes higher, the indoor temperature decreases proportionally in order to provide adequate thermal sensation to the occupants. The energy consumption are 260.30 kWh for the thermal comfort optimization strategy and 202.26 kWh for the thermal comfort and energy saving problem. In Fig. 7 (Solution 1), the higher energy consumption is due to the PMV Optimization, in this case the indoor thermal sensation provided to the occupants is almost near the

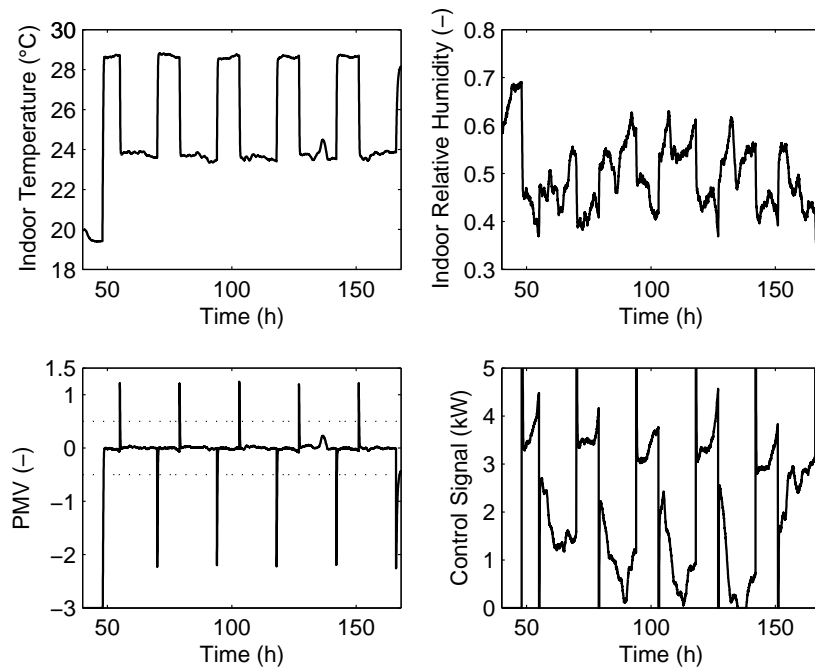

Figure 7. Case Study II - Indoor temperature, indoor relative humidity, PMV and control signal for the algorithm based on PMV optimization.

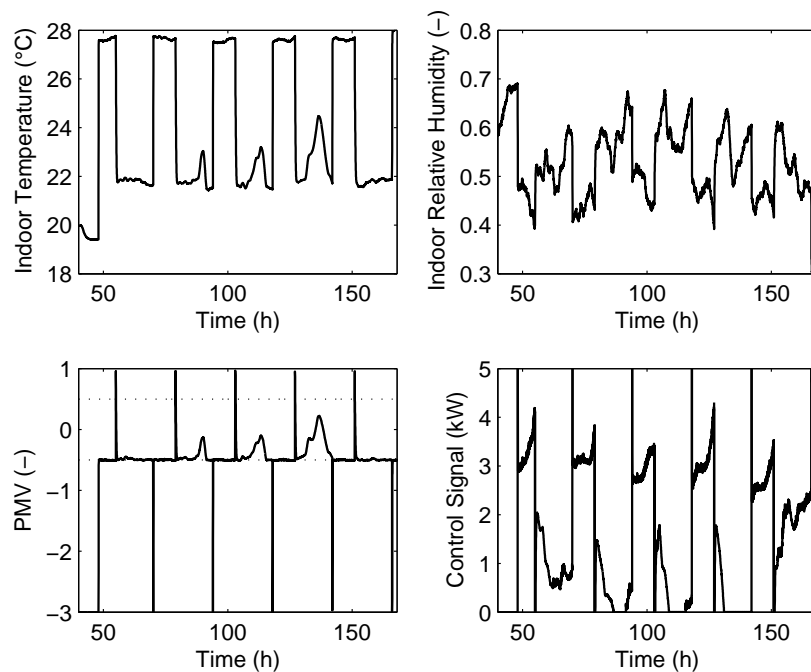

Figure 8. Case Study II - Indoor temperature, indoor relative humidity, PMV and control signal for the algorithm based on setting PMV signal boundaries minimizing energy consumption.

optimum solution ($PMV = 0$). However, in Fig. 8 (Solution 2), the controller is able to maintain the PMV signal within acceptable bounds [ASHRAE, 2001], providing thermal comfort and reducing energy waste.

Fig. 9 shows the situation where no adaptation on the PMV-based controller is taken into account. This highlights that the main advantage of this controller is the possibility of considering global model for thermal comfort, regardless the changes of individual parameters, and take advantage of such information when available.

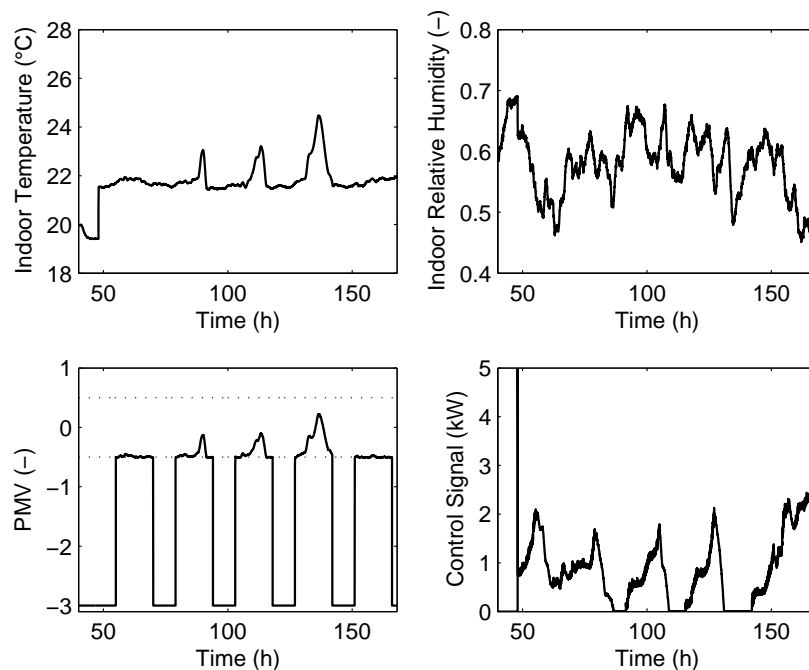

Figure 9. Variations on the indoor temperature, indoor relative humidity and PMV when different personal parameters are adopted.

5 CONCLUSIONS

In this paper, the indoor thermal comfort control problem in a single-zone building equipped with a HVAC system was analyzed. Two MBPC algorithms to optimize room air conditions focused on thermal comfort and/or energy savings by using only-one-actuator system associated to heating/cooling equipment have been presented.

The proposed algorithms were based on defining thermal comfort by using the PMV index. They were also classified between those that consider only thermal comfort optimization and those that additionally provide energy savings. All control strategies, which have been presented in this work, reached their goals in order to provide better indoor thermal comfort conditions to the occupants. The PMV-based controllers are well adapted in situations where at least a rough estimator of the occupants activity can be obtained.

Simulation results of two case studies, by using the Curitiba weather data file, have shown that the control algorithms presented in this paper can simultaneously promote thermal comfort and energy consumption reduction maintaining 100% of the time in the comfort zone. Due to the ability of the PMV controller to adapt to the individual parameters, it has been shown that it can provide a better global performance in terms of both thermal comfort control and energy consumption.

6 ACKNOWLEDGEMENTS

The authors thank CAPES (Coordenação de Aperfeiçoamento de Pessoal de Nível Superior) of the Secretariat of Education of Brazil, FINEP (Financiadora de Estudos e Projetos) and CNPq (Conselho Nacional de Desenvolvimento Científico e Tecnológico) of the Secretariat of Science and Technology of Brazil for support of this work.

7 REFERENCES

- ASHRAE, 2001, Atlanta, GA, American Society of Heating, Refrigerating and Air Conditioning Engineers, Atlanta, GA.
- Camacho, E. F. and Bordns, C., 1995, "Model Predictive Control in Process Industry", Springer Verlag.
- Clarke, D. W., editor, 1994, "Advances in Model Based Predictive Control", Oxford University Press, UK.
- EIA, 2004, Energy Information Administration, www.eia.doe.gov.
- Fanger, P. O., 1970, "Thermal Comfort", McGraw-Hill Inc., New York, USA.
- Freire, R. Z., 2006, Advanced Control Strategies Applied to HVAC Systems for Thermal Comfort Optimization - (In Portuguese), Master's thesis, PPGEPS/CCET/PUCPR - Pontifical Catholic University of Paraná - Brazil.
- Freire, R. Z., Oliveira, G. H. C., and Mendes, N., 2005a, Development of Single-Zone Predictive Equations Using Linear Regression for Advanced Controllers Synthesis, "Proc. of the 9th Building Simulation Conference (IBPSA'05)", Vol. 1, Montreal, Canada.

- Freire, R. Z., Oliveira, G. H. C., and Mendes, N., 2005b, Thermal Comfort Based Predictive Controllers for Building Heating Systems, "Proc. of the 16th IFAC World Congress", Prague, Czech Republic.
- Freire, R. Z., Oliveira, G. H. C., and Mendes, N., 2006, Non-Linear Predictive Controllers for Thermal Comfort Optimization and Energy Saving, "Proc. of the IFAC on Energy Saving Control in Plants and Buildings (ESC'06)", pp. 87–92.
- Gagge, A. P., Fobelets, A. P., and Berlund, L. G., 1986, A standard predictive index of human response to the thermal environment, "ASHRAE Transactions", Vol. 92, pp. 709–731.
- Gouda, M. M., Danaher, S., and Underwood, C. P., 2001, Thermal Comfort Based Fuzzy Logic Controller, "Building Serv. Eng. Res. Technol.", Vol. 22, No. 4, pp. 237–253.
- Hamdi, M. and Lachiver, G., 1998, A Fuzzy Control System Based on the Human Sensation of Thermal Comfort, "Proc. of IEEE International Conference on Fuzzy Systems", pp. 487–492, USA.
- IEA, 2003, International Energy Agency - Annex 41 - Whole Building Heat, Air and Moisture Response MOIST-ENG, Technical report, Modelling, Belgium.
- Jones, B. W., 2002, Capabilities and limitations of thermal models for use in thermal comfort standards, "Energy and Buildings", Vol. 1, No. 34, pp. 653–659.
- Kolokotsa, D., Tsiavos, D., Stavrakakis, G. S., Lalaitzakis, K., and Antonidakis, E., 2001, Advanced fuzzy logic controllers design and evaluation for buildings occupants thermal-visual comfort and indoor air quality satisfaction, "Energy and Buildings", Vol. 33, pp. 531–543.
- Liang, J. and Du, R., 2005, Thermal Comfort Control Based on Neural Network for HVAC Application, "Proc. of the IEEE Conference on Control Applications", pp. 819–824, Toronto, Canada. (CCA'05).
- Ljung, L., 1999, "System Identification: Theory for the user", Prentice Hall, Inc., 2 edition.
- Mendes, N., Oliveira, R. C. L. F., and Santos, G. H., 2005, Energy Efficiency and Thermal Comfort Analysis Using the Powerdomus Hygrothermal Simulation Tool, "Proc. of the 9th Building Simulation Conference (IBPSA'05)", Vol. 1, pp. 9–16, Montreal, Canada.
- Nassif, N., Kaji, S., and Sabourin, R., 2003, Two-objective online optimization of supervisory control strategy, "Proc. of the Eighth Building Simulation Conference (IBPSA'03)", Vol. 1, pp. 927 – 934, Eindhoven, Netherlands.
- Salsbury, T., 2005, A Survey of Control Technologies in the Building Automation Industry, "Proc. of the 16th IFAC World Congress", pp. 331–341, Prague, Czech Republic.
- Smith, C., 1991, "A Transient Three-Dimensional Model of the Human Thermal System", PhD thesis, Department of Mechanical Engineering, Kansas State University, Manhattan, KS, USA.
- Yonezawa, K., Yamada, F., Wada, Y., and Hanada, Y., 2000, Comfort Air-Conditioning Control for Building Energy-Saving, "Proc. of the Industrial Electronics Society - IECON. 26th Annual Conference of the IEEE", Vol. 3, pp. 1737–1742, Nagoya, Japan.