

## CONTROL OF A WIND GENERATION SYSTEM APPLIED TO OCEAN BASINS

**Luis Antonio Parra, [luisparra@usp.br](mailto:luisparra@usp.br)**

**Eduardo Aoun Tannuri, [eduat@usp.br](mailto:eduat@usp.br)**

Escola Politécnica, University of São Paulo  
Department of Mechatronics Engineering  
Av. Prof. Mello Moraes, 2231, Cidade Universitária – SP

**Abstract.** The present paper describes the implementation of the speed control applied to a wind generation system. The generator is installed in the academic wave tank of the Naval Architecture and Ocean Engineering Department of University of São Paulo. The set-point of the control system is the desired wind speed in a pre-defined distance from the fans. The set-point can be either a static value (representing a constant wind) or a time-varying value (representing a wind gust). The wind speed is measured by an anemometer, and this signal is used as feed-back for the controller as well as for the calibration of the speed. The actuation system is composed by the frequency-inverters and fans, and their dynamics are considered for the tuning of the controller. A PC based control and supervisory system is developed and the validation of the wind speed controller is presented in the paper.

**Keywords:** *Wind-Generation, Wind-Speed, Fan-Control*

### 1. INTRODUCTION

The ITTC (International Towing Tank Conference) is a worldwide association that has a responsibility for prediction of the hydrodynamic performance of ships and marine installations based on the results of physical and numerical modeling.

According to the ITTC there is a need for research and development to predict the behavior of marine structures, whether floating or with foundations, like ships at anchor or dynamically positioned under the action of waves, currents and winds. This prediction is done through modeling and simulation of generation of waves and currents in deep or not deep water, wave absorption, reduction of waves and also the integration of the test model with numerical modeling (ITTC, 2005; ITTC, 2009). With respect to the action of the winds, this research deals with developing a system to simulate them by means of a closed loop control of ventilators in a wave tank to analyze its effects on ships or offshore structures and also of study its use in power generation.

Wind is the displacement of air masses caused by differences of pressure between two distinct regions. The air is accelerated from higher to lower pressure. Such pressure differences have a thermal origin, tropical regions, which receive the sun's rays almost perpendicularly, are warmer than the polar regions; hence the hot air is found in low altitudes in tropical regions tends to rise and be replaced by a mass of cooler air that shifts in the polar regions.

The two major driving factors of large scale winds are the differential heating between the equator and the poles (due the absorption of solar energy) and the rotation of the planet, moreover, near the Earth's surface, friction causes the wind to be slower than at higher altitude.

It is understood the need to determine, through the construction of models and realization of simulations, the effects of wind actions on structures and ships so that we can design them in order to make them safer.

### 2. PROPOSAL

The proposal of this work is to design a system to simulate the wind variations in a test tank. It will be followed some recommendations of the ITTC to this work.

According to the ITTC there are three methods that can be used for the simulation of wind models:

- 1 - One set (arrays) of fans, the most popular and widely accepted;
- 2 - Fans united directly to the model (model attached);
- 3 - Using a system of springs (spring-weight system).

The chosen method in laboratory is the use of a set of fans.

#### 2.1. Equipment and facilities

The work is performed at the test tank of the Department of Naval Architecture and Ocean Engineering of Escola Politécnica (University of São Paulo) and uses the resources available in this laboratory such as computers, inverters, and fans system (Figure 1). The array of seven fans moves along the tank allowing approximating to the model to be tested. The system can also move up and down to adjust the height of the fans. Every fan is installed on a mobile base that allows you to vary the wind direction.

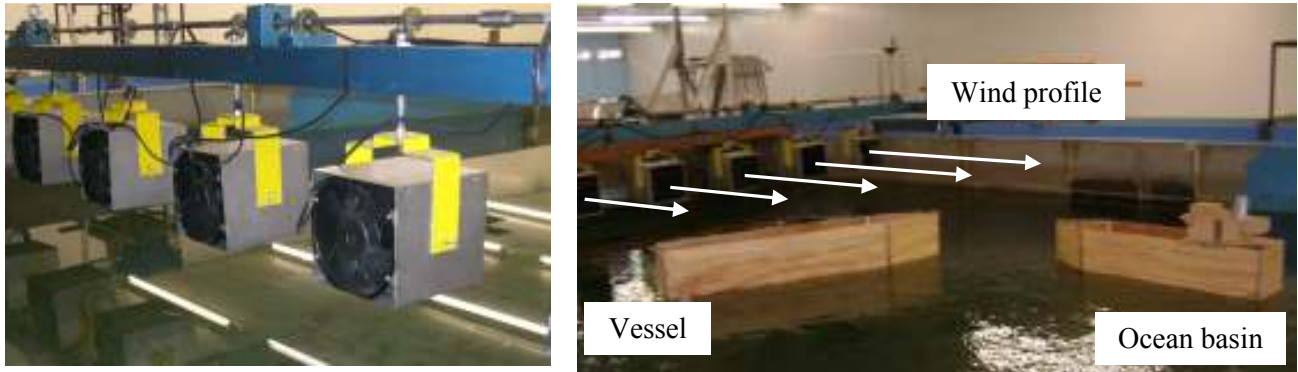

Figure 1. (Left) Details of the fans; (Right) Fans being used in an experiment

A frequency inverter is used to command each motor. The reference rotation is given by an external analog signal (0~5V). Wind is measured by an anemometer, with an analog output proportional to wind speed. An AD/DA converter is used to interface with the computer. Finally, Matlab/Simulink software with real-time feature (Daga, 2011) is used to implement the control logic (Figure 2).

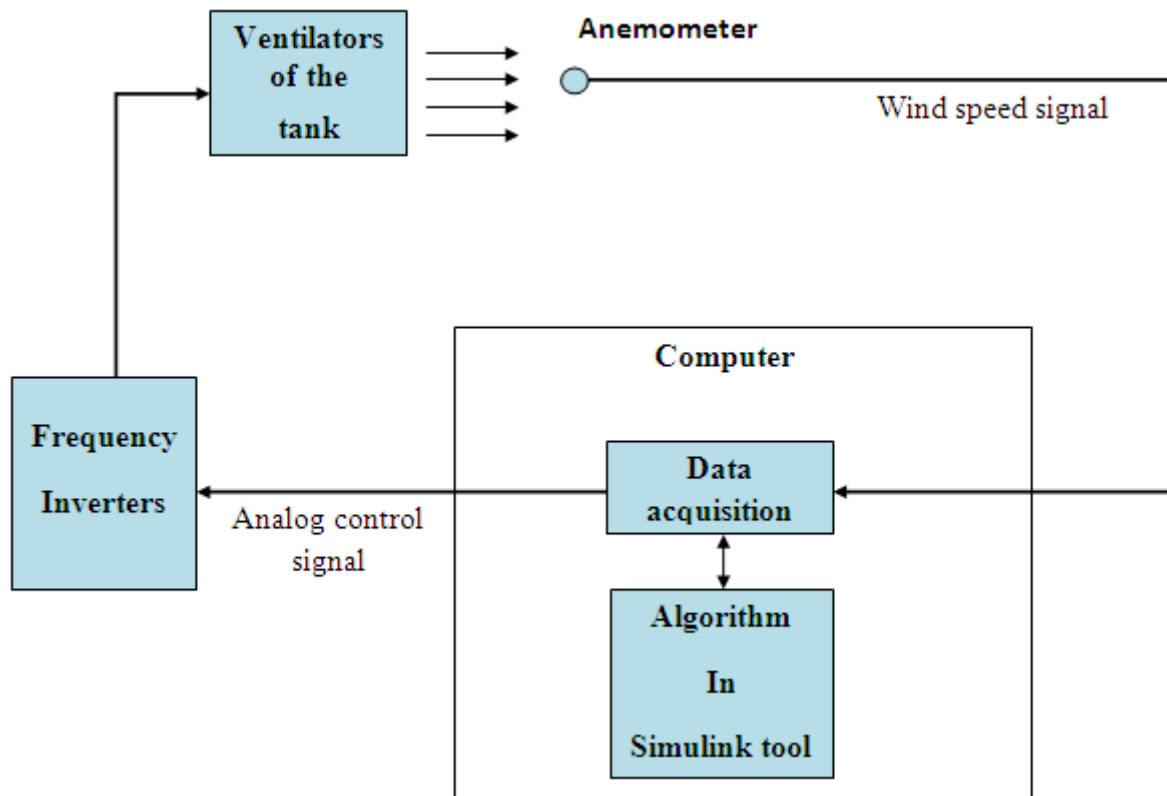

Figure 2. Block diagram of the wind control system

### 3. DETERMINATION OF THE MODEL

#### 3.1. Transfer Function

Simulink/Matlab software was initially implemented in the computer to send a signal to the remote inputs of the inverters that control the ventilators of the tank. The program also receives the signal measured from an anemometer placed in front of the ventilators, where a hive-like structure aligns the profile of wind speed on the blower outlet (Figure 3). The anemometer was placed at four distances, 0.5, 1.0, 1.5 and 2.0 m, from the ventilators to measure the wind speed.

For each distance, a step signal, variable from 0 to 5.0 V was applied from the Simulink block to the inverters, in order to verify the performance of the wind speed. This initial test was used to do the identification of the system.

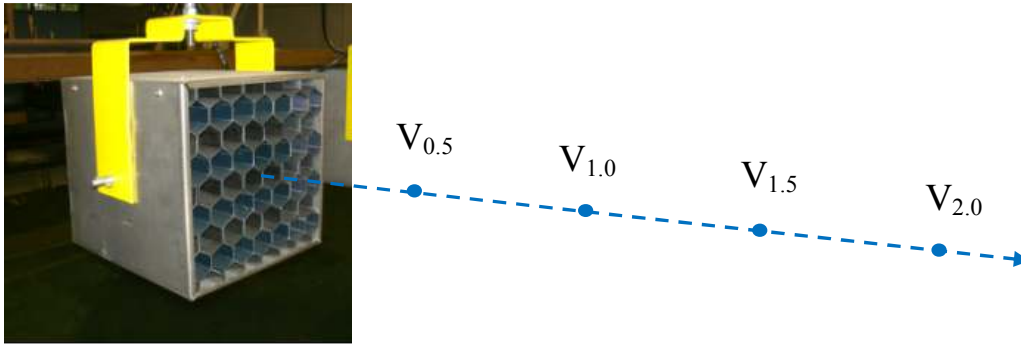

Figure 3. Distances of the anemometer from the fans to measure the wind speed.

With the obtained data, the wind steady-state speed  $V$  as a function of signal  $U$  applied to the fans was obtained, for each distance (Figure 4):

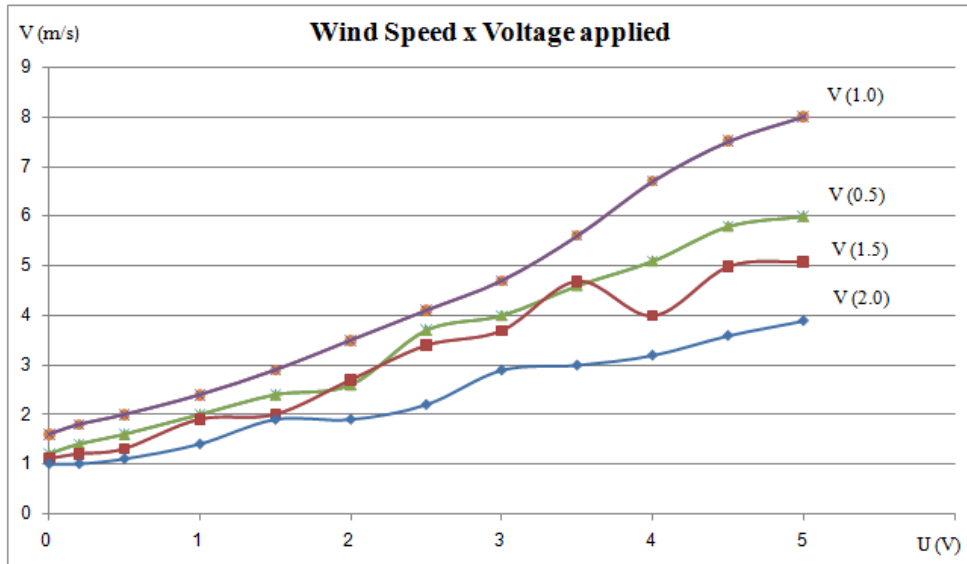

Figure 4. Wind speed for each distance from the fan

For each line we have the following equations of the wind speed ( $v$ ):

$$v(0.5) = 1.0038.u + 1.0495 \quad (\text{measure from 0.5 m of the fan}) \quad (1)$$

$$v(1.0) = 1.3090.u + 1.2116 \quad (\text{measure from 1.0 m of the fan}) \quad (2)$$

$$v(1.5) = 0.8627.u + 1.0168 \quad (\text{measure from 1.5 m of the fan}) \quad (3)$$

$$v(2.0) = 0.6011.u + 0.8709 \quad (\text{measure from 2.0 m of the fan}) \quad (4)$$

An average equation was traced to represent the model of the plant. The idea, in the next section, is to develop a robust controller using the "average" model.

$$v(\text{average}) = 0.9442.u + 1.0372 \quad (5)$$

Considering a first order dynamics, the relation between the applied tension  $U$  and the wind speed is given by:

$$\frac{v}{U} = \frac{\hat{K}}{\hat{\tau}s+1} \Rightarrow \hat{\tau} \cdot \dot{V} + V = \hat{K} \cdot U \Rightarrow \dot{V} = \left[ \frac{-1}{\hat{\tau}} \right] \cdot V + \left[ \frac{\hat{K}}{\hat{\tau}} \right] \cdot U \Rightarrow \dot{V} = f + b \cdot U \quad (6)$$

Based on the equation obtained we implemented the model for the plant (Figure 5). A delay was also included, due to the travel time of the air from the fan to the anemometer.

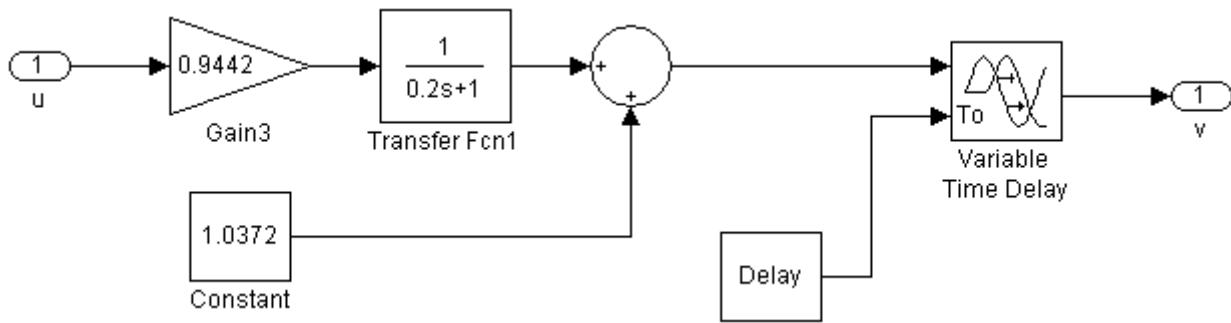

Figure 5. Model of the plant

A signal step of 5.0 V was applied in the input U of the model, considering the distance of 0.5 m. The output V was verified according to the Figure 6.

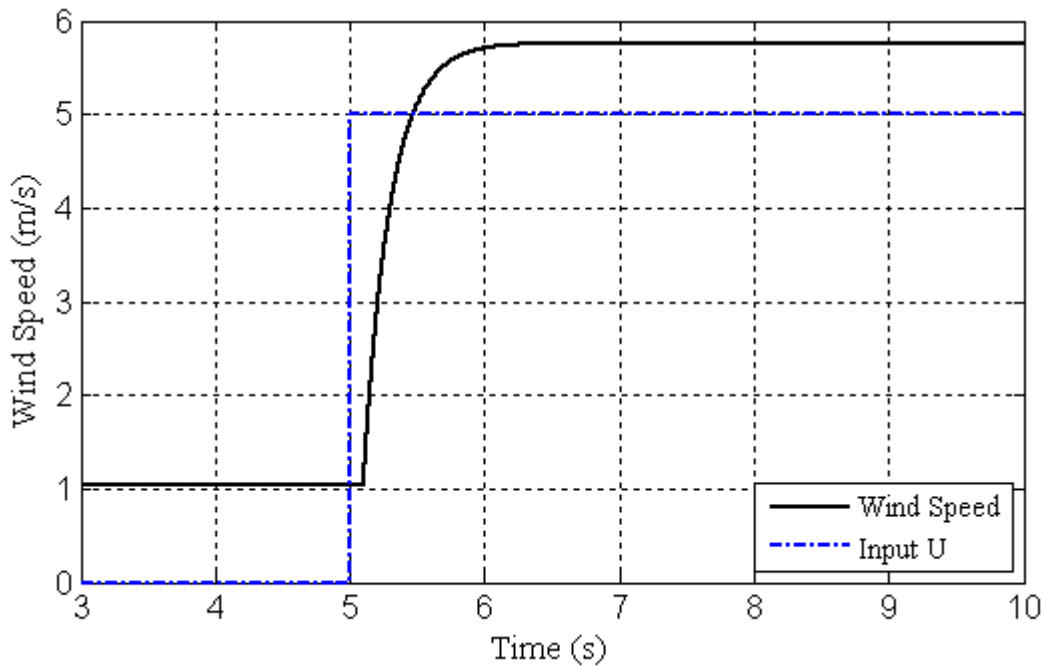

Figure 6. Response to a signal step of 5.0 V from 0.5m of the fan

The first order system has two parameters (“b” and “f”) with uncertainty. Thus, with some known values, with the estimation of the others unknown values and some considerations, we can determine the parameters of the system in order to implement a control for it. For this we adopted some calculation based on the Slotini / Li (1991).

**3.1.1. Treatment of the equation  $\dot{V} = f + b \cdot U$  with respect to “f”:**

$$f = \left[ \frac{-1}{\tau} \right] \rightarrow \text{(Unknown, but we have its limits)} \quad (7)$$

Considering  $\tau = 0.20$  s, with variation of  $\pm 20\%$ , we have:

$$\tau_{max} = 0.24 \text{ s} \quad (8)$$

$$\tau_{min} = 0.16 \text{ s} \quad \Rightarrow \quad (9)$$

$$f_{min} = \frac{-1}{\tau_{max}} V = \frac{-1}{0.24} \Rightarrow \boxed{f_{min} = -4.16V} \quad (10)$$

$$f_{max} = \frac{-1}{\tau_{min}} V = \frac{-1}{0.16} \Rightarrow \boxed{f_{max} = -6.25V} \quad (11)$$

$$\hat{f} = \left[ \frac{-1}{\tau} \right] V = \left[ \frac{-1}{0.20} \right] V \Rightarrow \text{(Considering } \tau = 0.2 \text{ s)} \quad (12)$$

$$\Rightarrow \boxed{\hat{f} = -5.00V} \quad (13)$$

$$|f - \hat{f}| = |6.25V - 5.00V| = > \quad (14)$$

$$|f - \hat{f}| = 1.25V = F \text{ (error)} \quad (15)$$

**3.1.2. Treatment of the equation  $\dot{V} = f + b \cdot U$  with respect to “b”:**

$$b = \left[ \frac{K}{\tau} \right] \rightarrow \text{(Unknown, but we have its limits)} \quad (16)$$

From the obtained equations (1), (2), (3) and (4), K changes from 0.60 to 1.31.  
 Considering  $\tau = 0.20$  s, with variation of  $\pm 20\%$ , we have:

$$\tau_{max} = 0.24 \text{ s} \quad (17)$$

$$\tau_{min} = 0.16 \text{ s} \quad (18)$$

Thus, we can extract:

$$b_{min} = \frac{K_{min}}{\tau_{max}} = \frac{0.60}{0.24} \Rightarrow \boxed{b_{min} = 2.50} \quad (19)$$

$$b_{max} = \frac{K_{max}}{\tau_{min}} = \frac{1.31}{0.16} \Rightarrow \boxed{b_{max} = 8.20} \quad (20)$$

According Slotine / Li (1991), we can estimate b by geometric mean of b limits:

$$\hat{b} = \sqrt{b_{min} \cdot b_{max}} \quad (21)$$

$$\Rightarrow \hat{b} = \sqrt{2.50 \times 8.20} \quad \Rightarrow \boxed{\hat{b} = 4.50} \quad (22)$$

Calling  $\beta$  the gain margin of the design:

$$\beta = \left( \frac{b_{max}}{b_{min}} \right)^{1/2} \quad (23)$$

$$\beta = \left( \frac{8.20}{2.50} \right)^{1/2} \Rightarrow \boxed{\beta = 1.80} \quad (24)$$

### 3.2. Control

Considering that we have unknown parameters, but estimated, we can use the sliding control mode.  
 Applying the control law:

$$\boxed{u = \frac{1}{\hat{b}} \cdot [-\hat{f} - K \cdot \text{Sgn}(s)] + \dot{V}d} \quad (25)$$

### 3.3. Sliding surface

$$S = V - Vd \Rightarrow \quad (26)$$

$$\Rightarrow \dot{S} = \dot{V} - \dot{V}d = f + b \cdot u - \dot{V}d$$

$$\dot{S} = f + b \cdot \left[ \frac{1}{\hat{b}} (-\hat{f} - K \cdot \text{Sgn}(s) + \dot{V}d) \right] - \dot{V}d \Rightarrow \quad (27)$$

$$\dot{S} = f - b \cdot \hat{b}^{-1} \cdot \hat{f} - b \cdot \hat{b}^{-1} \cdot K \cdot \text{Sgn}(s) + b \cdot \hat{b}^{-1} \cdot \dot{V}d - \dot{V}d \quad (28)$$

According Slotine/Li (1991):

$$\frac{1}{2} \cdot \frac{dS^2}{dt} = \dot{S} \cdot S = (f - b \cdot \hat{b}^{-1} \cdot \hat{f}) \cdot S - b \cdot \hat{b}^{-1} \cdot K \cdot |S| - \dot{V}d \cdot (1 - b \cdot \hat{b}^{-1}) \cdot S \leq -\eta \cdot |S| \quad (29)$$

$$(\text{Since } \text{Sgn}(S) \cdot S = |S|) \quad (30)$$

Considering  $S > 0$ , we can rewrite:

$$(f - b \cdot \hat{b}^{-1} \cdot \hat{f}) - b \cdot \hat{b}^{-1} \cdot K - \dot{V}d \cdot (1 - b \cdot \hat{b}^{-1}) \leq -\eta \Rightarrow \quad (31)$$

$$\Rightarrow K \geq [\eta + (f - b \cdot \hat{b}^{-1} \cdot \hat{f}) - \dot{V}d \cdot (1 - b \cdot \hat{b}^{-1})] \cdot b^{-1} \cdot \hat{b} \quad (32)$$

And thus:

$$\boxed{K \geq \beta \cdot (F + \eta) + (\beta - 1) \cdot |\hat{u}|} \quad (33)$$

Where:

$$\boxed{\hat{u} = -\frac{1}{\hat{b}} + \dot{V}d} \quad (34)$$

With the calculated value before, and considering:

- $\eta = 1$
- Maximum value of  $\emptyset = 0,1$  m/s (where  $\emptyset$  is a boundary layer thickness)
- Using  $\text{Sat}\left(\frac{S}{\emptyset}\right)$  instead of  $\text{Sgn}(s)$  to eliminate the chattering:

$$\Rightarrow \text{Sat}\left(\frac{S}{\emptyset}\right) = \text{Sat}\left(\frac{S}{0,1}\right) = \text{Sat}(10S) \quad (35)$$

We have:

$$K \geq 1.8(1.25V + 1) + (1.8 - 1)|\hat{u}| \Rightarrow \quad (36)$$

$$\Rightarrow \hat{u} = -\frac{(-5.V)}{4.5} + \dot{V}d \quad \boxed{\Rightarrow \hat{u} = 1.1V + \dot{V}d} \quad (37)$$

## 4. SIMULATION OF THE CLOSED-LOOP WIND CONTROL SYSTEM

With the equations and calculated parameters, a sliding mode control was implemented in the modeled plant.

#### 4.1. Applying the Smith predictor

The dead time caused by the distance from the ventilators to the anemometer affects the performance of the sliding control. Beyond the increase of the settling time, the transport delay causes an overshoot due the high time that the output signal arrives in the sum block of the controller.

In order to solve this problem we included a controller called “Smith predictor”. Design by Otto J.M. Smith, this control allows minimizing the effects of the dead time of the system.

The block diagram of this control is shown in the Figure 7 where we have:

- $G_a(s)$  is the average model of the plant obtained in the equation 5;
- $G(s)$  is the plant to be controlled;
- $T$  is the transport delay of the system;
- $\widehat{G}_c(s)$  is the sliding control adjusted after included the Smith predictor.

The idea of this predictor is to implement a feedback around the controller to compensate the dead time.

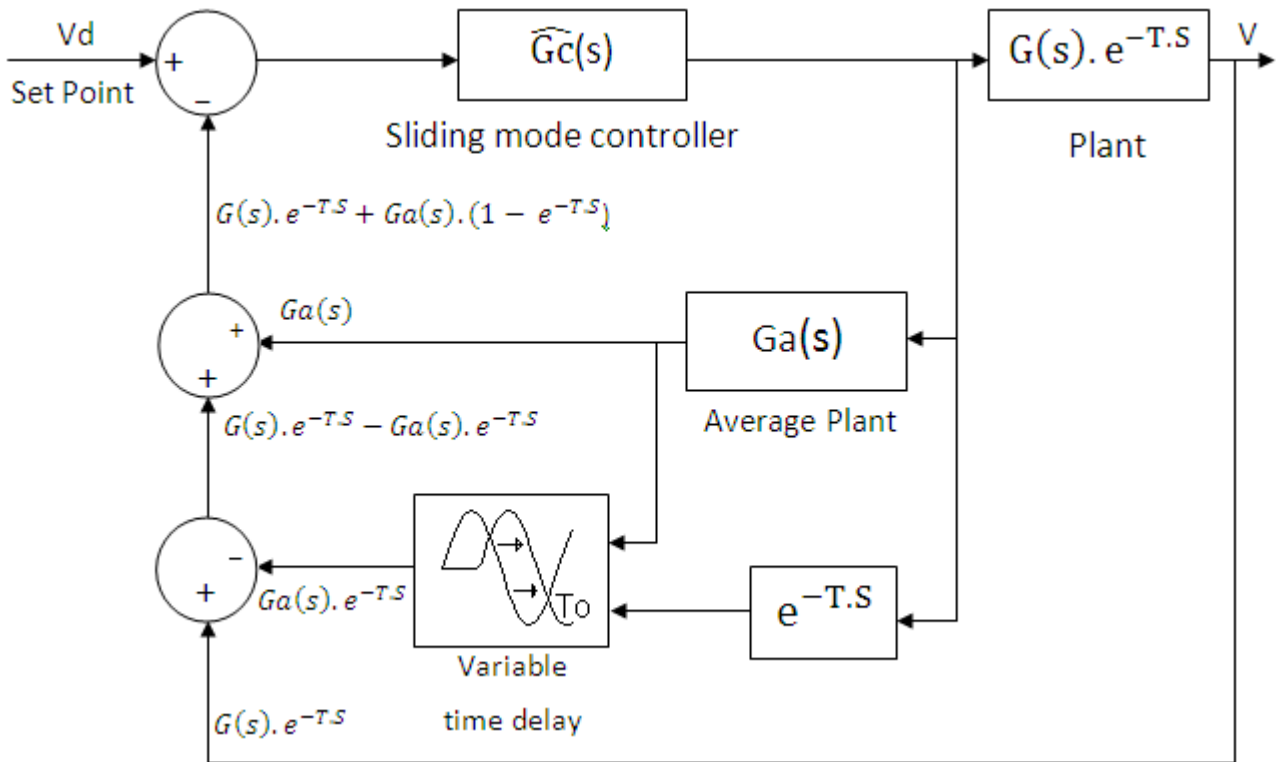

Figure 7. Block diagram of the Smith predictor applied together with the sliding control in the plant

The transfer function of this closed loop control is:

$$\frac{V(s)}{Vd(s)} = \frac{\widehat{G}_c(s).G(s).e^{-T.S}}{1+(1-e^{-T.S}).\widehat{G}_c(s).G_a(s)+\widehat{G}_c(s).G(s).e^{-T.S}} \quad (38)$$

If occurs the plant to be controlled ( $G(s)$ ) is exactly equal the average plant ( $G_a(s)$ ), we can rewrite:

$$\frac{V(s)}{Vd(s)} = \frac{\widehat{G}_c(s).G(s).e^{-T.S}}{1+(1-e^{-T.S}).\widehat{G}_c(s).G(s)+\widehat{G}_c(s).G(s).e^{-T.S}} \quad (39)$$

$$\frac{V(s)}{Vd(s)} = \frac{\widehat{G}_c(s).G(s).e^{-T.S}}{1+\widehat{G}_c(s).G(s)(1-e^{-T.S}+e^{-T.S})} \quad (40)$$

$$\frac{V(s)}{Vd(s)} = \frac{\widehat{G}_c(s).G(s)}{1+\widehat{G}_c(s).G(s)} e^{-T.S} \quad (41)$$

After including the Smith predictor, working together the sliding mode control, simulations was done and the parameters of the control system were adjusted.

A 5.0 m/s step signal was applied and the response of the system for the distances of 0.5, 1.0, 1.5 and 2.0 m is shown in figure 8.

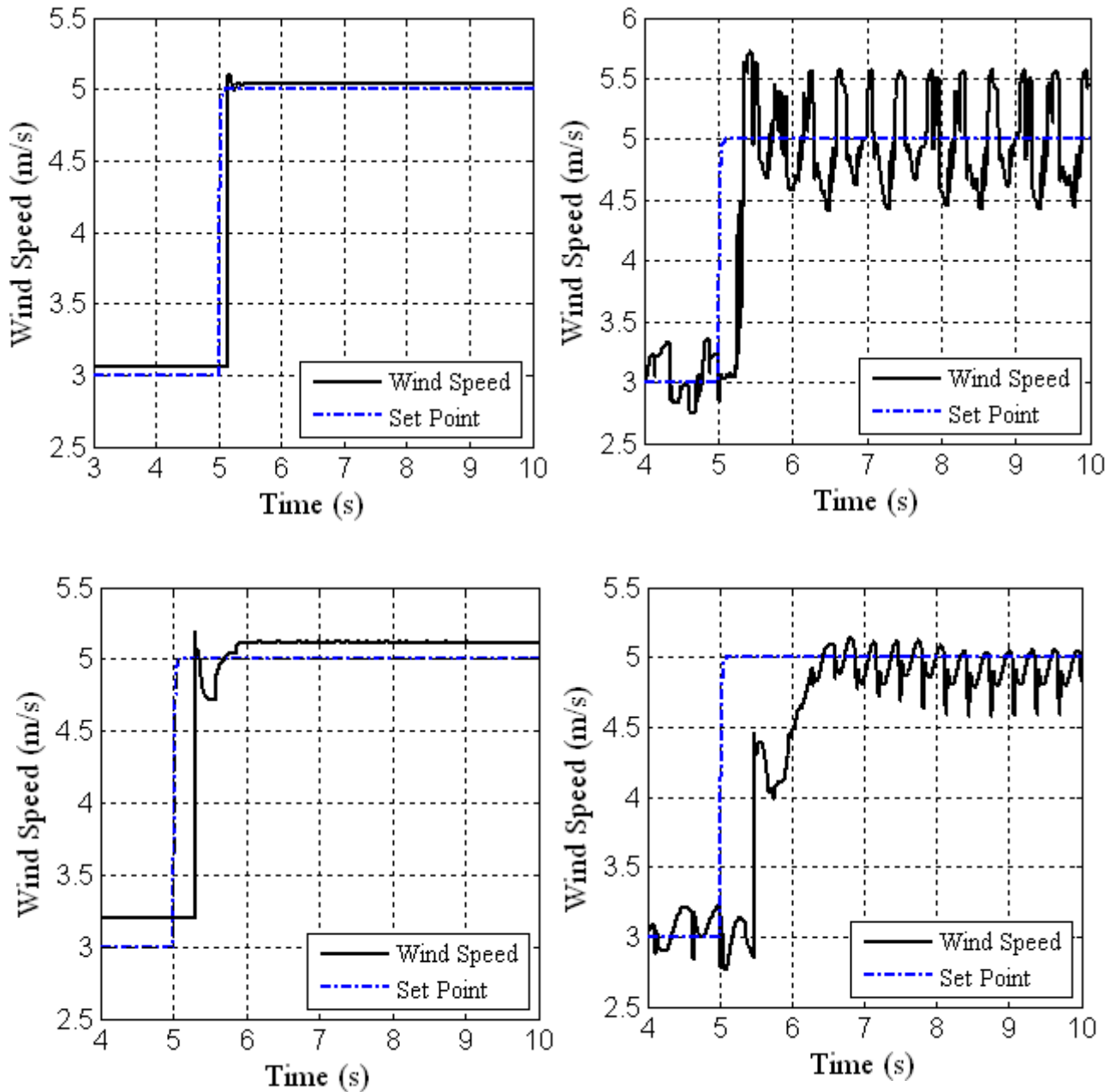

Figure 8. Response to a step signal for the distances of 0.5, 1.0, 1.5 and 2.0 m, after applying the Smith predictor

The Smith predictor minimized the effects of the delay in the output response, improvement the settling time and the overshoot, but even with the inclusion of this control we observe from Figure 8 that as we increase the distance from the fan to the sensor the system doesn't follow according the desired set point.

The worst performance for the distance of 1.0m is related to the fact that the model of the velocity for such distance is the most divergent compared to the average model.

Also, to reduce the distortion of the output signal, the boundary layer thickness  $\delta$  was increased and this action caused an offset in the output signal.

We continue investigating means to obtain a better response for the system.



#### 4.2. Response time

A sinusoidal signal was applied as a set point of the system and the output response was verified for two situations:

1) **Increasing the frequency of the input signal (Figure 9).**

Considering the distance of 0.5 m, as we increase the frequency of the input signal (for times of 5, 3, 2 and 1 s), we observed that the distortion occurred in the output response and the sliding control didn't act efficiently as planned.

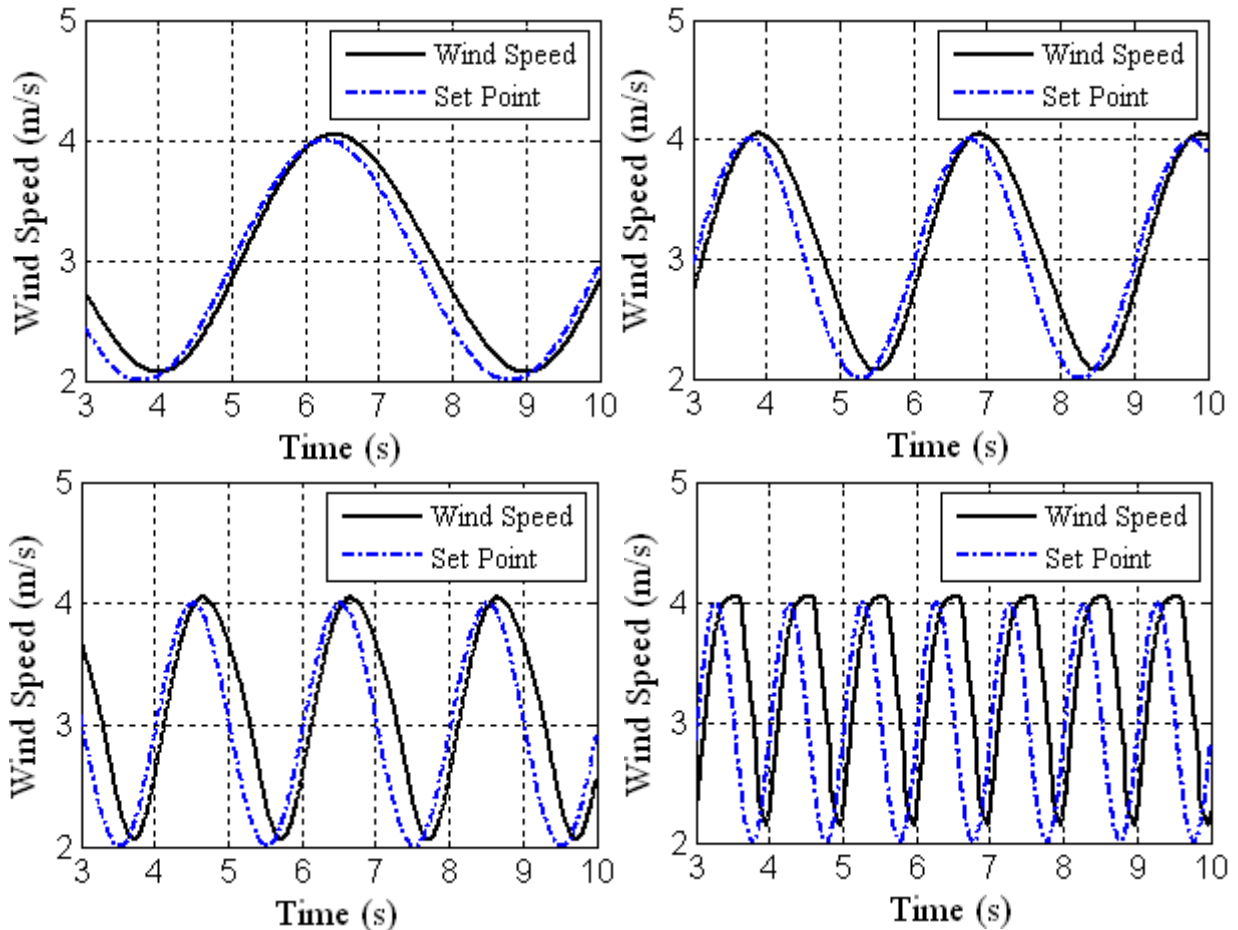

Figure 9. Output response to a sin signal considering the times of 5, 3, 2 and 1 s

2) **Increasing the distance from the wind sensor to the ventilators (Figure 10).**

As we increased the distance from 0.5 to 1.0 m, a noise occurred in the output. To minimize this disturb, we changed the boundary layer thickness  $\delta$  from 0.10 to 1.25 m/s, consequently, resulted an offset in the output response.

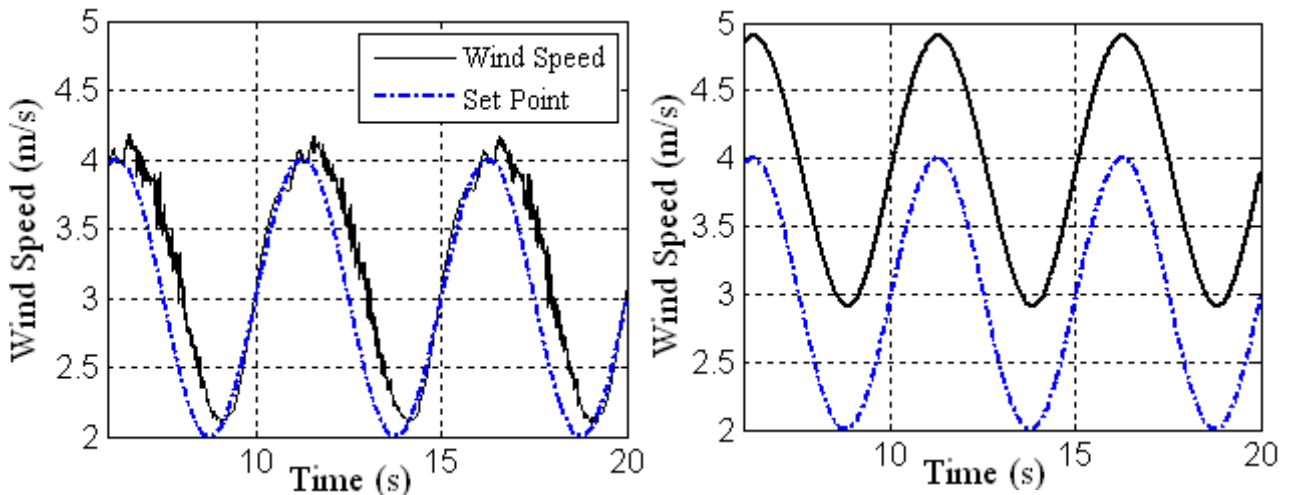

Figure 10. Output response considering the boundary layer thickness  $\delta$  of 0.10 m/s and 1.25 m/s

### 4.3. Simulating wind gusts

Since the parameters were calculated, the sliding control was adjusted and respecting the sampling time of the system, a random signal were applied as a set point of the control to simulate wind gusts, for the distance of 0.5 m (Figure 11). We can observe that the output signal follow according to the desired wind profile.

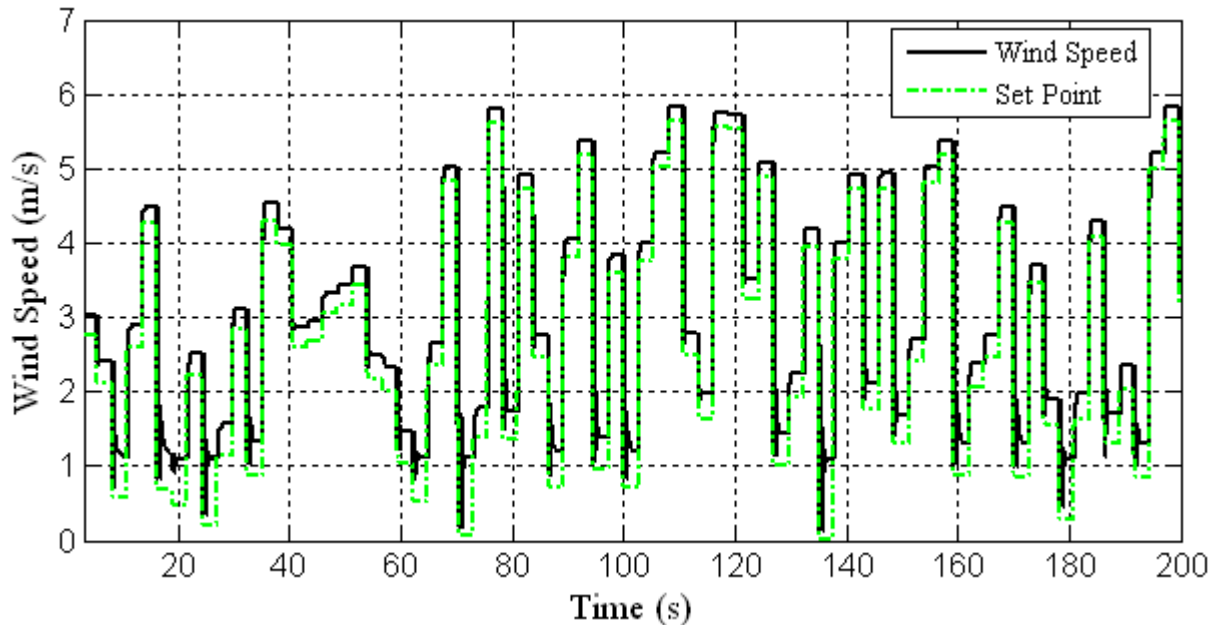

Figure 11. Response to a random signal simulating wind gusts

## 5. CONCLUSION

A sliding mode control combined with a Smith predictor can reduce the effects of the transport delay due the distance from the ventilators to the sensor, since the delay affects drastically the performance of this control and it must be considerate at the moment of design the system. Moreover, some parameters can influence the faithful reproduction of some wind profiles in the area of the tank, as the distance between the fans, proximity to the walls, proximity to the water, etc.

The next procedure is to do the experimental validation of the obtained results by the calculations and simulations and to reproduce the better response of the system.

## 6. REFERENCES

- ANSI/AMCA, 1999, "Laboratory Methods of Testing Fans for Aerodynamic Performance Rating", United States.
- Blessmann, J., 1998, "Introduction to the study of the dynamic action of the wind", Porto Alegre, Brazil.
- Carvalho, F.N., 2007, "Wind Generation Study for Scale Model of Offshore Structures in Oceanic Tank, Ph.D. dissertation", Rio de Janeiro, Brazil.
- Daga L. Leonardo, 2007, "Daga's Warehouse", Italy, 28 Jan 2011. < <http://digilander.libero.it/LeoDaga/index.htm>>.
- ITTC, 1999, "Model Testing on Tanker-Turret Systems", Proceedings of the 23rd ITTC, Vol. 1, Denmark, 694 p.
- ITTC, 2005, "Modeling and Simulation of Wind Environments", Proceedings of the 24th ITTC, Vol. 1, United Kingdom, 311 p.
- NBR 06123, 1988, "Force Due the Winds", Brazil, 66 p.
- Slotine, J.J.E., Li, W., 1991, "Applied Nonlinear Control", United States, 460 p.
- WEG, 2007, "CFW 10 frequency inverter manual", Brazil, 111 p.

## 7. RESPONSIBILITY NOTICE

The authors are the only responsible for the printed material included in this paper.